

1

Smart Sensor Systems: Why? Where? How?

Johan H. Huijsing

1.1 Third Industrial Revolution

Automation has three phases:

- (1) Mechanization;
- (2) Informatization;
- (3) Sensorization.

Humans have always tried to extend their capabilities. See Figure 1.1. Firstly, they extended their mechanical powers. They invented the steam engine, the combustion engine, the electric motor, and the jet engine. Mechanization thoroughly changed society. The first industrial revolution was born.

Secondly, they extended their brains, or their ratio. They invented means for artificial logic and communication: the computer and the internet. This informatization phase is changing society again, where we cannot yet fully predict the end result.

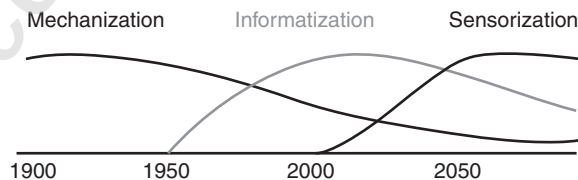

Figure 1.1 Sensorization: the third automation revolution

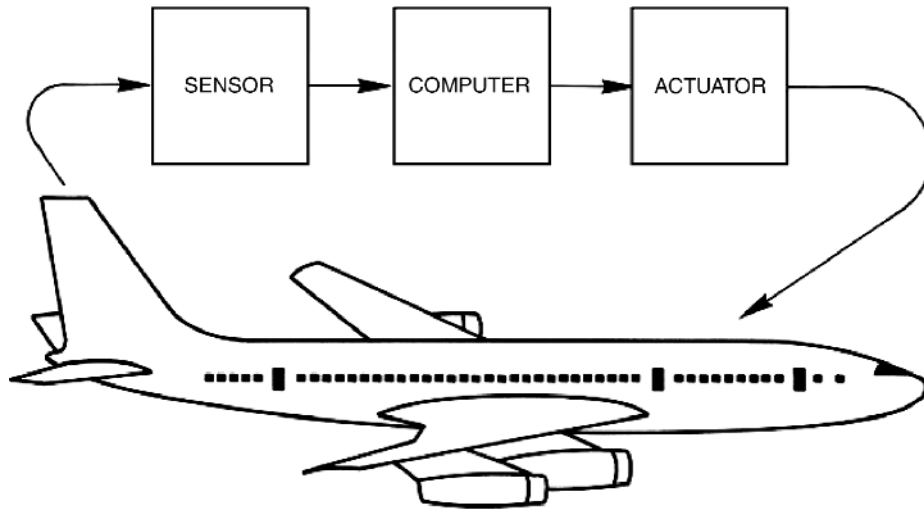

Figure 1.2 A fully automated airplane showing the triplet of mechanization, informatization and sensorization

However, this is not all. By inventing sensors, humans are now learning to artificially expand their senses. Sensorization together with mechanization and informatization will bring about the third industrial revolution of full automation or robotization.

A good example is the automated flight control system of a modern airplane (Figure 1.2). It includes many sensors to monitor the flight. The computers process the signals, compare them with the designed values, and provide control signals for the engines, rudders, and flaps that move the plane. This triptych of mechanics, computers, and sensors allows the plane to fly on autopilot.

If aircraft can fly automatically, why then can we still not have our car drive us to work by simply telling it to do so? Because the sensor system for an autodriver still weighs too much, is too bulky, and too costly to manufacture. So before we can apply sensorization to smart cars, smart homes, and industrial production machines, we must reduce the costs, size, and weight of the sensor system. This effort is the subject of our present challenge to develop Integrated Smart Sensors, as shown in Table 1.1.

Table 1.1 Integrated smart sensors

Challenge:	enabling the measurement of many physical and (bio)chemical signals
Requirements:	low cost, low size, low weight, low power, self-test, bus or wireless communication
HOW:	integrating sensors, actuators and smart interface electronics, preferably in one IC-package

1.2 Definitions for Several Kinds of Sensors

We will now provide definitions for several kinds of sensors as follows:

- Sensors
- Smart Sensors
- Integrated Smart Sensors
- Smart Sensors Systems

1.2.1 Definition of Sensors

Sensors transform signals from different energy domains to the electrical domain. Figure 1.3 classifies signals in six domains.

The uppermost domain in Figure 1.3 contains all signals of the radiant or optical domain. Optical sensors are able to translate these signals into electrical signals, which are depicted in the lowest domain. An example is an image sensor that translates a picture into an electrical signal. The next domain, to the right is the mechanical signal domain. For example, an accelerometer or airbag sensor is able to translate mechanical acceleration into an electrical signal. Similarly, a temperature sensor translates the temperature into an electrical signal. Even electrical sensors exist. They translate electrical signals into other electrical signals, for instance to measure accurately the voltage difference between two skin electrodes on the chest of a patient. To the lower left is the magnetic domain. A Hall plate is able to convert a magnetic signal into an electrical signal. And finally, from the chemical and biochemical domain sensors are able to translate these signals into electrical ones. Examples are pH sensors and DNA sensors.

The physical effects of sensors can be described by differential equations on energy or power containment [1]. Parameters of cross-effects between different energy domains describe the cross-sensitivities of a sensor between these signal domains. These effects are shown in Table 1.2, which places the physical sensor effects in a system. On the left-hand side, we find the sensor input signal domains. At the top there are the output signal domains. All effects on the left/upper-right/lower diagonal refer to effects within one signal domain. An example is photoluminescence within the radiation domain. All effects in the column with electrical output signals describe sensor effects, for example photoconductivity. All effects in the row with an electrical signal as input describe actuator effects.

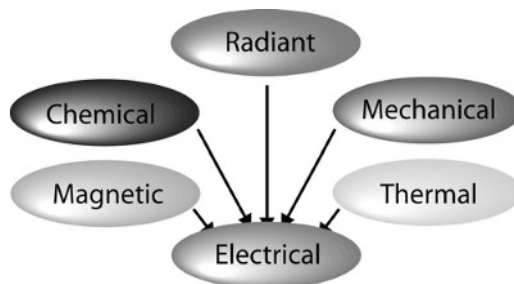

Figure 1.3 Sensor classification according to six signal domains

Table 1.2 Physical sensor effects [1]

In/Out	Radiant	Mechan.	Thermal	Electrical	Magnetic	Chemical
<i>Rad.</i>	Photo-luminan.	Radiant pressure	Radiant heating	Photo-cond.	Photo-magn.	Photo-chem.
<i>Mech.</i>	Photo-elastic effect	Conservation of moment	Friction heat	Piezo-electricity	magnetostriction	Pressure-induced explos.
<i>Therm.</i>	Incan-descence	Thermal expansion	Heat conduction	Seebeck effect	Curie-Weiss law	Endotherm raction
<i>Electr.</i>	Inject. Luminan.	Piezo-electr.	Peltier effect	PNjunction effect	Ampere's law	Electrolysis
<i>Magn.</i>	Faraday effect	Magnetostriction	Ettinghausing effect	Hall effect	Magnetic induction	
<i>Chem.</i>	Chemo-lumin.	Explosion reaction	Exothermal reaction	Volta effect		Chem. reaction

Sensors can be further divided into passive (self-generating) and active (modulating) types. This is depicted in Figure 1.4. Passive sensors such as the electrodynamic microphone obtain their output energy from the input signal; active sensors on the other hand, such as the condenser microphone, obtain it from an internal power source. Active sensors can achieve a large power gain between the input and output signals. The sensor cube in Figure 1.5 shows a three-dimensional space of input, output, and power-source signals for sensors. A further classification of sensors is shown in Figure 1.6. Two classes can be distinguished: open systems, in which there is no feedback, and closed-loop systems, with feedback. A spring balance is a good mechanical example of the first; a chemical balance is a good example of the second.

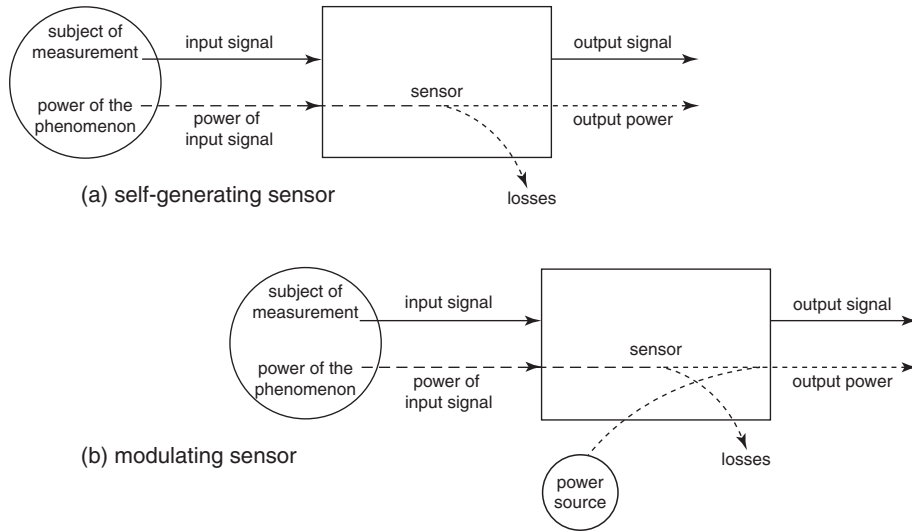

Figure 1.4 Self-generation and modulating sensors [2]

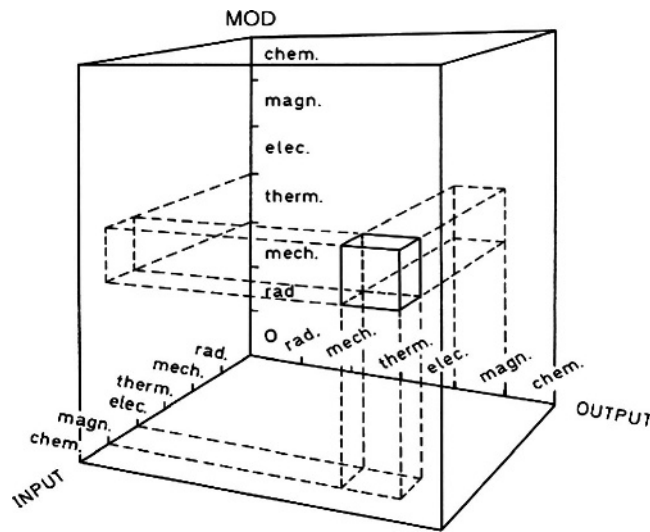

Figure 1.5 Sensor cube [1]

To measure with a chemical balance, weights have to be placed on the balance scale in order to bring the pointer to zero. The advantage of this system is that the actual sensor only needs to sense accurately around the zero point. The feedback placing of weights determines the value. In an open sensor system, the sensor has to provide the linearity and accuracy of the signal transfer all by itself.

Figures 1.7 and 1.8 depict the multitude of materials that can be chosen for sensors. Semi-conductors are becoming increasingly popular as a sensor material because of their stable

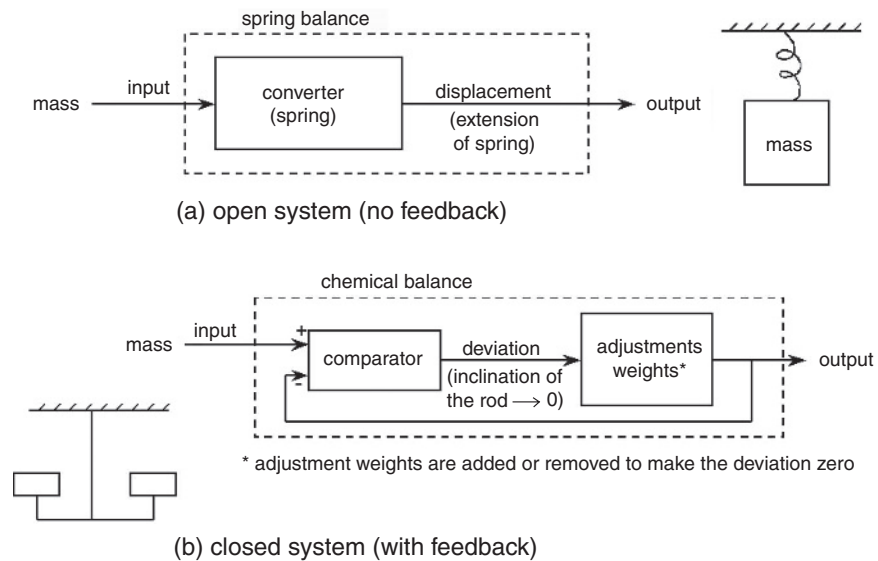

Figure 1.6 Open and closed loop sensor systems [2]

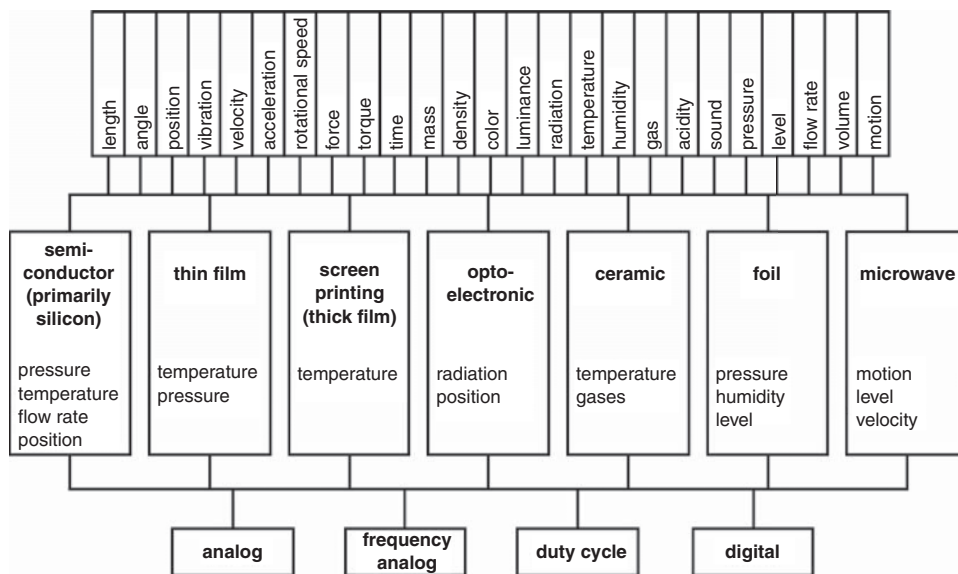

Figure 1.7 Sensor materials [3]



Figure 1.8 Which one? [2]

crystalline structure and because its standardization in mass fabrication is being improved; and because of their low price.

The production economics of sensors is often hampered by the multitude of sensor parameters to be measured. This is illustrated in Table 1.3.

Even for one parameter, such as pressure, there are many specifications: accuracy, sensitivity, noise, resolution, dynamic range, and environmental requirements. For this reason there are thousands of different pressure sensors on the market (see Figure 1.9).

Another complicating factor is the many output signal types of sensors. Some are listed in Table 1.4.

Further standardization and compacting is needed. The smart sensor is the solution (see Figure 1.10).

Table 1.3 Sensor parameters [3]

1. mechanical parameters of solids	2. mechanical parameters of fluids and gases	5. acoustic parameters	8. chemical parameters
<ul style="list-style-type: none"> • acceleration • angle • area • diameter • distance • elasticity • expansion • filling level • force • form • gradient • hardness • height • length • mass • mass flow rate • moment • movement • orientation • pitch • position • pressure • proximity • revolutions per minute • rotating velocity • roughness • tension • torque • torsion • velocity • vibration • way • weight 	<ul style="list-style-type: none"> • density • flow direction • flow velocity • level • pressure • rate of flow • vacuum • viscosity • volume 	<ul style="list-style-type: none"> • sound frequency • sound intensity • sound polarization • sound pressure • sound velocity • time of travel 	<ul style="list-style-type: none"> • cloudiness • composition • concentration • dust concentration • electrical conductivity • humidity • ice • impurities • ionization degree • molar weight • particle form • particle size • percentage of foreign matter • pH-value • polymerization degree • reaction rate • redox potential • thermal conductivity • water content
	3. thermal parameters	6. nuclear radiation	
	<ul style="list-style-type: none"> • enthalpy • entropy • temperature • thermal capacity • thermal conduction • thermal expansion • thermal radiation • thermal radiation temperature 	<ul style="list-style-type: none"> • ionization degree • mass absorption • radiation dose • radiation energy • radiation flux • radiation type 	
	4. optical parameters	7. magnetic & electrical parameters	
	<ul style="list-style-type: none"> • color • image • light polarization • light wave-length • luminance • luminous intensity • reflection • refractive index 	<ul style="list-style-type: none"> • capacity • charge • current • dielectric constant • electric field • electric power • electric resistance • frequency • inductivity • magnetic field • phase 	<ul style="list-style-type: none"> 9. other significant parameters • frequency • pulse duration • quantity • time

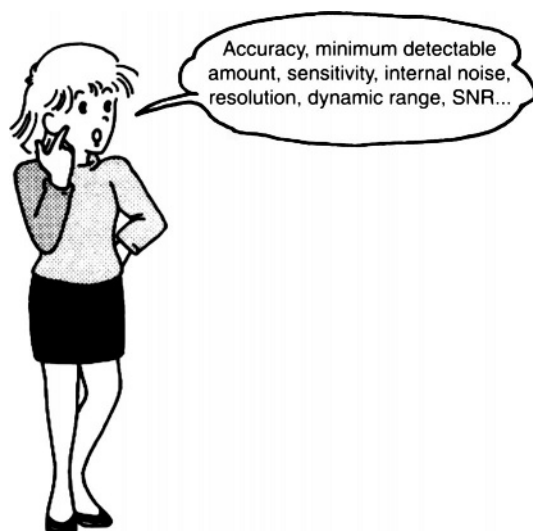

Figure 1.9 Sensitivity? Accuracy? [2]

Table 1.4 Non-standard sensor signals

Voltage:	Thermo Couple, Bandgap Voltage
Current:	Bip. trans., P.S.D., Radiation Detector
Resistance:	Strain-Gauge Bridge, Hall Sensor
Capacitance:	Humidity, Tactile, Accelerometer
Inductance:	(difficult on-chip)

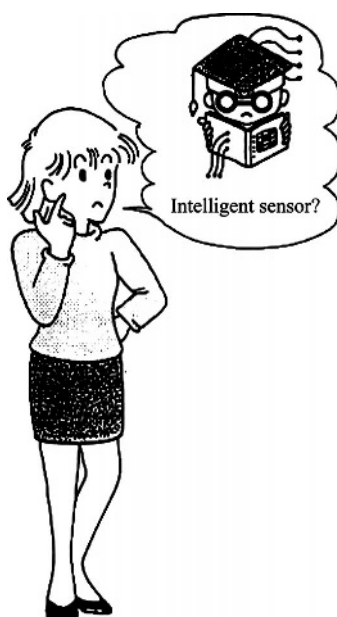

Figure 1.10 Smart sensor? [2]

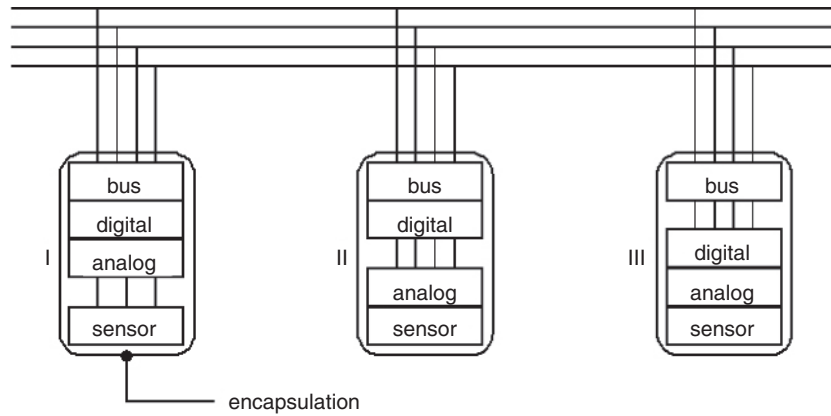

Figure 1.11 Hybrid smart sensors

1.2.2 Definition of Smart Sensors

If we combine a sensor, an analog interface circuit, an analog to digital converter (ADC) and a bus interface in one housing, we get a smart sensor. Three hybrid smart sensors are shown in Figure 1.11, which differ in the degree to which they are already integrated on the sensor chip. This calls for standardization. And hence the sensor must become smarter.

In the first hybrid smart sensor, a universal sensor interface (USI) can be used to connect the sensor with the digital bus. In the second one, the sensor and signal conditioner have been integrated. However, the ADC and bus interface are still outside. In the third hybrid, the sensor is already combined with an interface circuit on one chip that provides a duty cycle or bit stream. Just the bus interface is still needed separately.

At this level, still many output formats exist, as shown in Table 1.5.

1.2.3 Definition of Integrated Smart Sensors

If we integrate all functions from sensor to bus interface in one chip, we get an integrated smart sensor, as depicted in Figure 1.12.

Table 1.5 Standard sensor interface signals

Sign. Cond.:	Analog Voltage	0.5 V to 4.5 V
	Analog Current	4 mA to 20 mA
Sign. Conversion:	Frequency	2 kHz to 22 kHz
	Duty Cycle	10 % to 90 %
	Bit Stream	
	Bites	
Bus Output:	IS ² , I ² C	
	D ² B, Field, CAN	

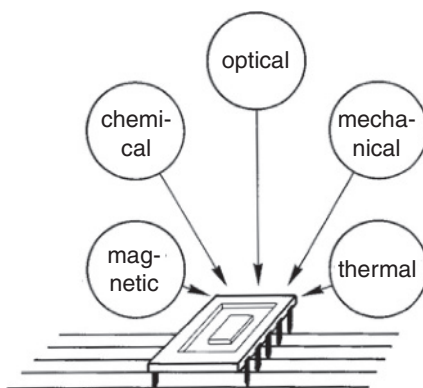

Figure 1.12 Integrated smart sensor

An integrated smart sensor should contain all elements necessary per node: one or more sensors, amplifiers, a chopper and multiplexers, an AD converter, buffers, a bus interface, addresses, and control and power management. This is shown in Figure 1.13.

Although fully integrating all functions will be expensive, mass-production of the resulting sensor can keep the cost per integrated smart sensor reasonable. Another upside is that the

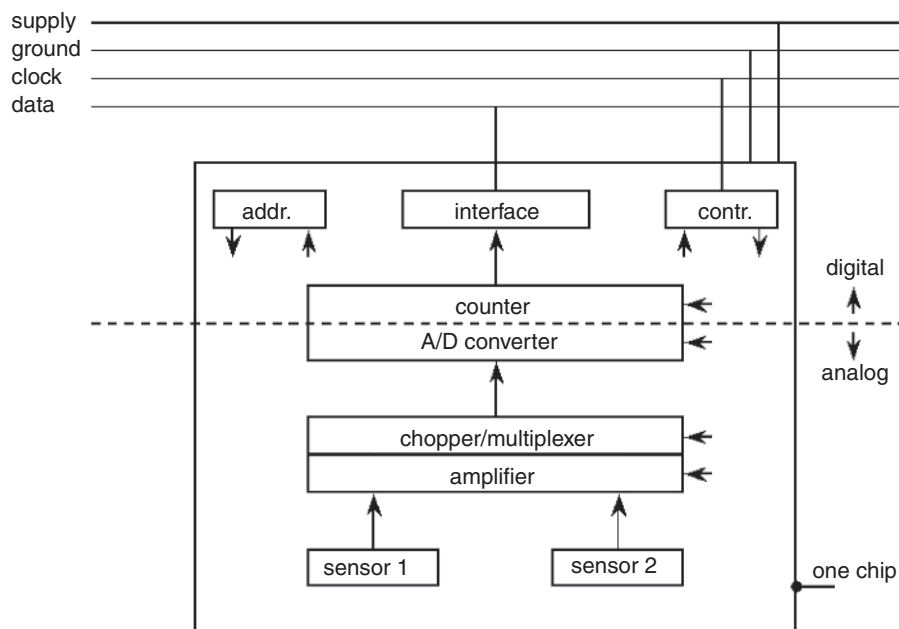
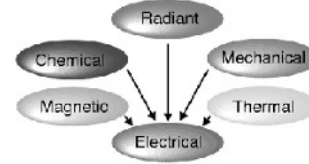

Figure 1.13 Functions of an integrated smart sensor

Table 1.6 Integrated Smart Sensors

Technology:	IC-compatible 3-D micro-structuring, Packaging
Radiant:	Image Sensors, Integrated adaptive optics
Mechanical:	Piezo-junction effects, Mechanical filters
Thermal:	Thermopile sensors, Absolute kT/q sensor
Electrical:	Capacitive sensors and actuators
Magnetic:	Spinning current Hall-plate sensors, High temperature sensors
Chemical:	DNA detectors, High Speed Screening



costs of installing the total sensor system can be drastically reduced because of the simple modular architecture.

However, for realizing all functions on one chip we must first integrate a diversity of sensors on one chip. For this purpose an IC-compatible three-dimensional micro-structuring technology is being developed. Table 1.6 contains a number of IC-compatible sensors presently being developed.

In addition, interface electronics has to be developed, suitable for integration on the sensor chip. Table 1.7 contains some examples of integrated smart sensors with on-chip interface electronics.

1.2.4 Definition of Integrated Smart Sensor Systems

Figure 1.14 depicts the evolution of integrated smart sensor systems with many intermediate steps. The greater the market for smart sensors of a certain type, the more integration is economically affordable for that type.

Our final dream is depicted in Figure 1.15. If we are also able to integrate a wireless power source and wireless communication, a whole new concept of ambiguous sensors will appear. Many sensors could then be used in cars, homes, clothes, and fields to obtain valuable information.

Table 1.7 Interface electronics for integrated smart sensors

Technology:	Low-power opamps, Low-power $\Sigma\Delta$ ADC's, Smart sensor bus system, Selftesting and Autocalibration
• Medical:	DNA Sensors, Multi-blood sensor, Catheter locating system
• Scientific:	Optical spectrometer, Adaptive mirror and LC systems, Wavefront sensor
• Industrial:	Universal transducer interface, Capacitive fingerprintsensor, Thermal windmeter, Absolute temperature sensor, High-Speed Chemical Analyzer, Spinning Current Hall Sensors, Accelerometer
• Computer Interface:	Capacitive human interfaces

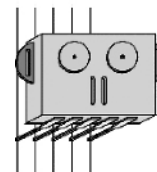

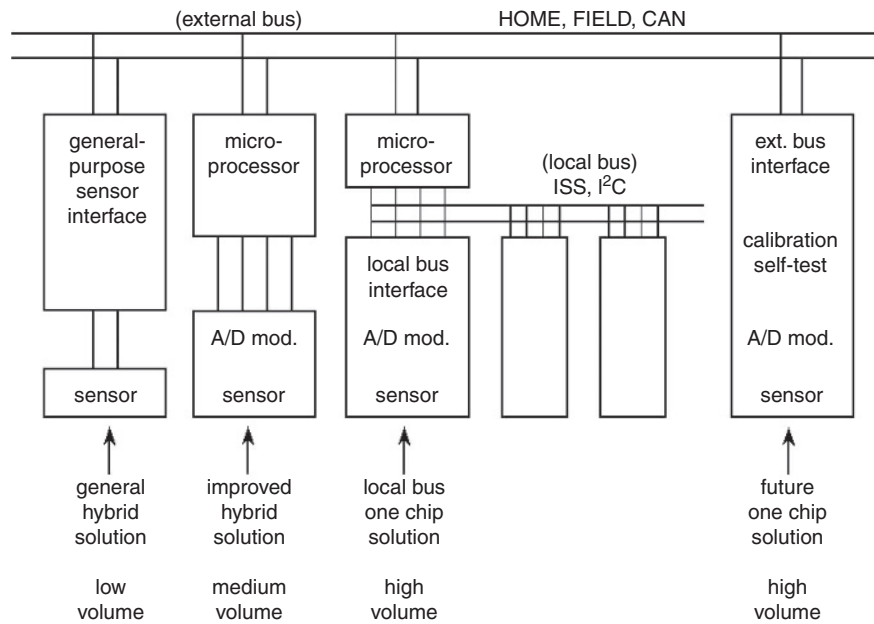

Figure 1.14 Smart sensor system evolution

1.3 Automated Production Machines

Integrated smart sensors will be applied in all areas of daily life: in smart homes and appliances, in smart cars, and in smart production machines. Table 1.8 shows the areas where integrated smart sensors are already being used in smart production machines and in professional monitoring of processes.

In the chemical or biochemical industry, many types of sensors are used to analyze chemical or biochemical substances. An example is the high-speed screening chip of Figure 1.16, which contains many nanoliter holes.

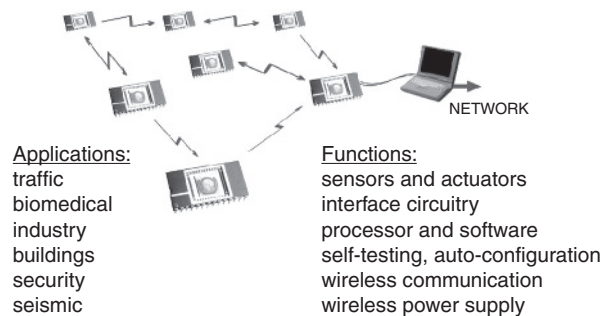

Figure 1.15 Autonomous microsensors

Table 1.8 Automated production machines and professional monitoring

(bio)chemical industry	traffic control
metal industry	environmental monitoring
car industry	health care
textile industry	health monitoring
food industry	security
building industry	office automation
agriculture industry	

Each hole contains a different chemical reagent. Also each hole contains a heater, a light source and a light detector. Only one drop of sample is required for analysis, because it can fill many nanoliter holes.

A study on sensors in the machine building industry from 1995 has shown the applications for which sensors are needed, see Figure 1.17.

In addition, the benefits of using sensors in the machine building industry are shown in Figure 1.18. It clearly shows an increase in automation, for instance to detect early failure diagnostics of the machines. Therefore, the electronics share of the production costs of machines is gradually increasing to about 10 % to 20 %, as shown in Figure 1.19.

In agriculture, more and more sensors are being used. In greenhouses for example, production is increasingly being automated through the introduction of climate and pest control, water and nutrient management, harvest robots, etc.

In car manufacturing, advanced robots are used to perform complicated assembly operations (Figure 1.20).

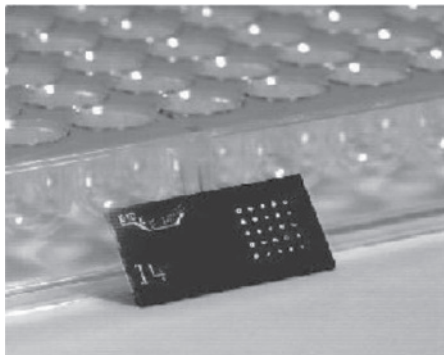

Applications:

- Medicine production
- Fermentation processes
- Analysis of body fluids

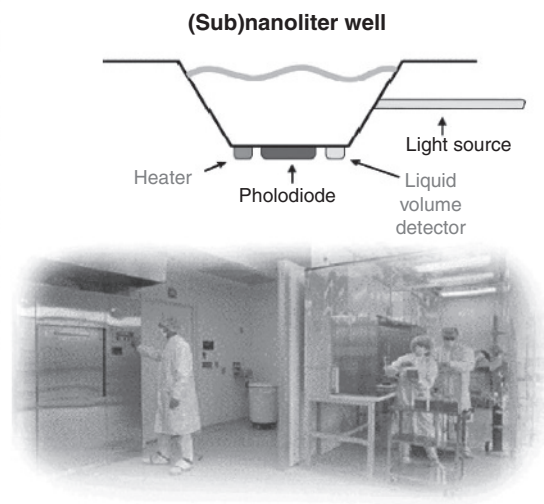

Figure 1.16 High-speed screening (Vellekoop)

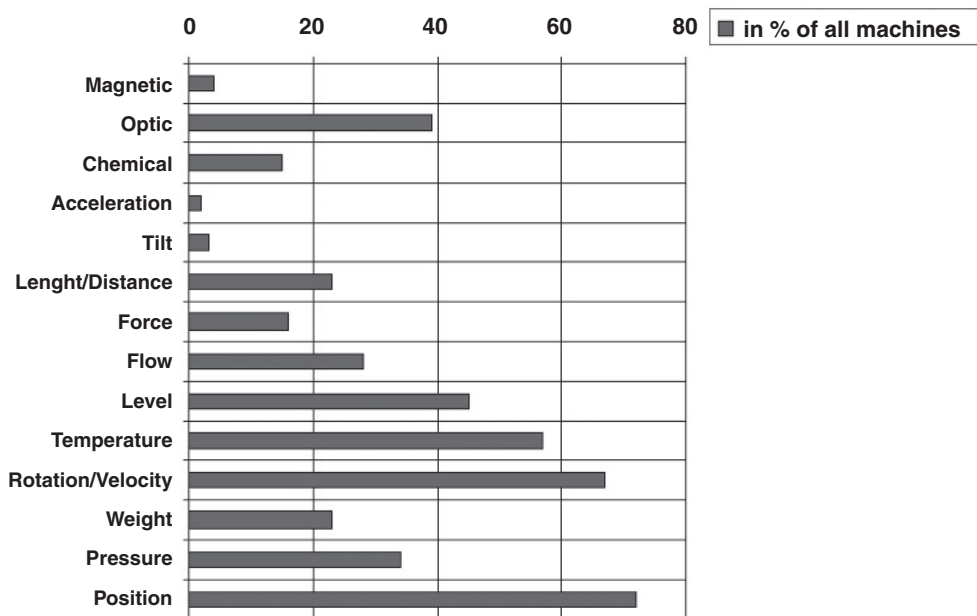

Figure 1.17 Sensors in machine building industry [3]

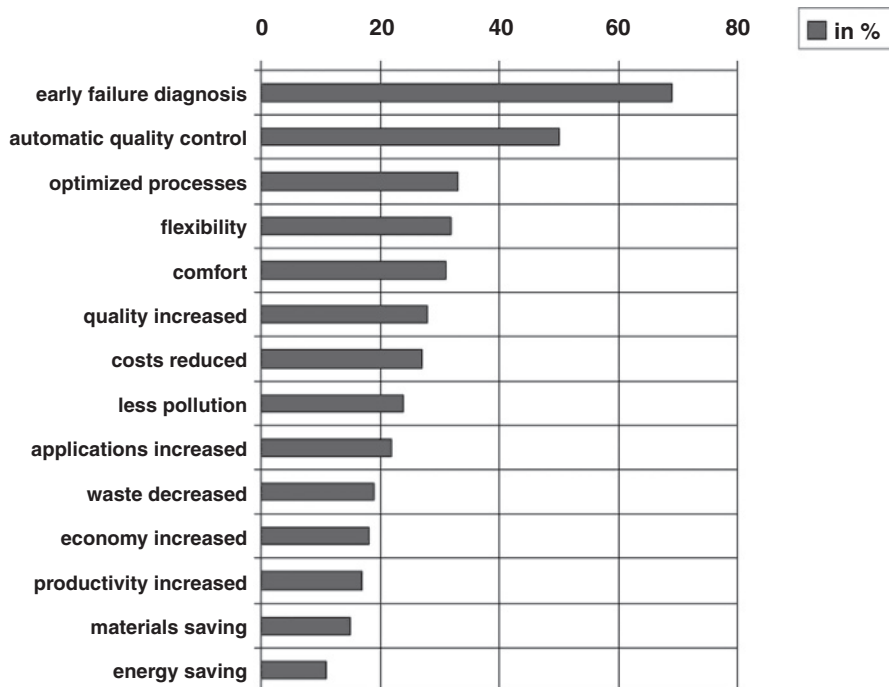

Figure 1.18 Benefits of using sensors [3]

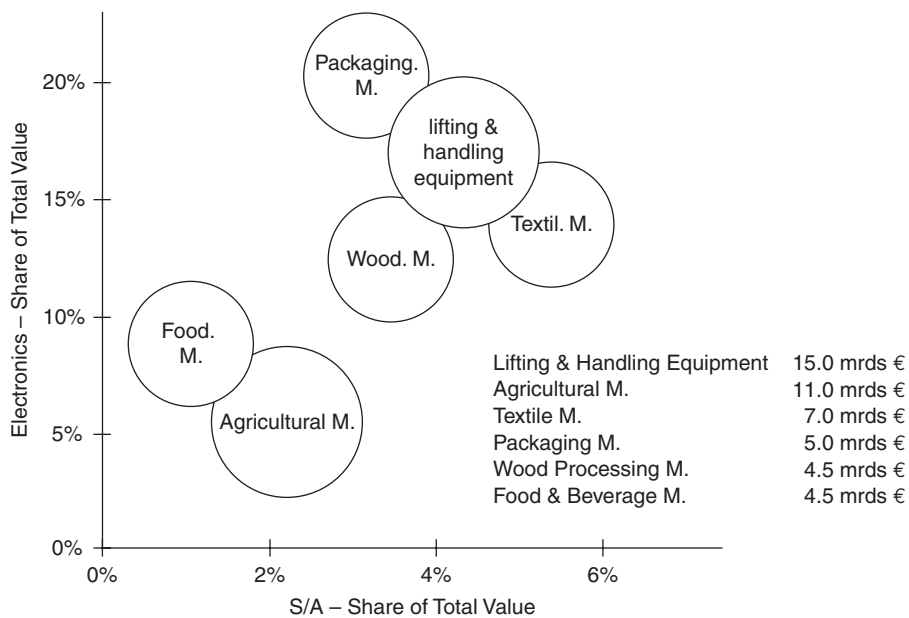

Figure 1.19 Sensor electronics share of total value in machine building [3]



Figure 1.20 Welding robot for car manufactory (courtesy of Rolan-Robotics)

1.4 Automated Consumer Products

Automated consumer products are rapidly emerging in the form of smart cars, smart homes, domestic appliances and toys, as follows:

- Smart Cars
- Smart Homes
- Smart Domestic Appliances
- Smart Toys

1.4.1 Smart Cars

Modern cars incorporated about 40 sensors in 2005, as depicted in Figure 1.21.

It will only be possible to accommodate more sensors if a distributed sensor bus is used instead of a star-connected sensor system. Only smart sensors make this economically viable. Otherwise the car breaks down under the load of wires (Figure 1.22).

1.4.2 Smart Homes

Many sensors have been built-in in the ‘home of the future’, erected in Rosmalen in the Netherlands in 1988, see Figure 1.23.

Like cars, houses can only accommodate many sensors if a distributed bus system is used instead of a point-to-point network (Figure 1.24).

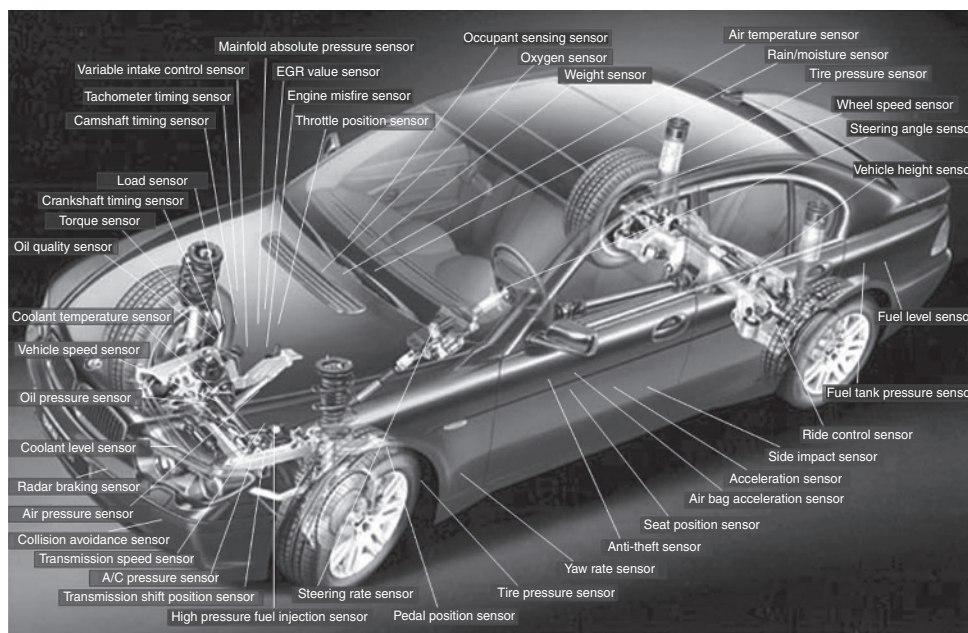

Figure 1.21 Sensors in a car

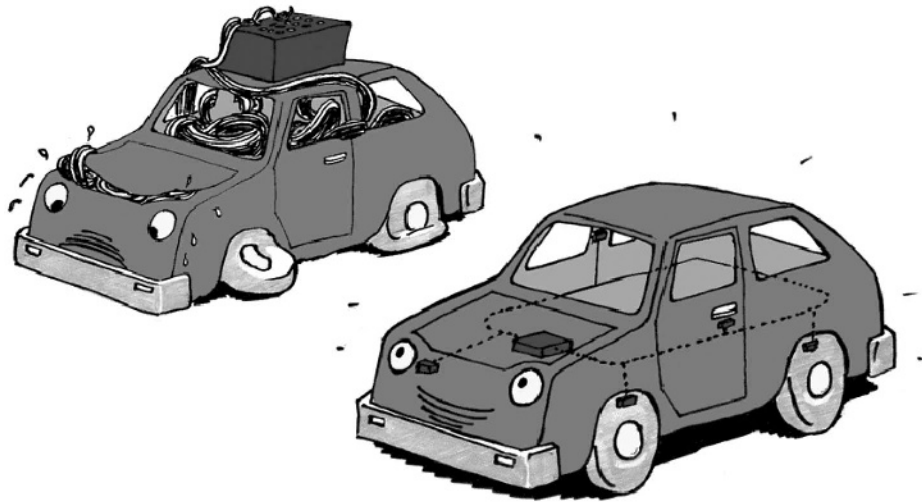

Figure 1.22 Star-connected and distributed-bus sensor systems

1.4.3 Smart Domestic Appliances

Domestic appliances still do not take over all the housework. But the time will come when the vacuum cleaner will automatically move from its socket once a week and vacuum the rooms, without running over a cat or knocking over a vase. It will vacuum until the carpet is clean and no longer, and will automatically return to its socket for recharging (Figure 1.25).

The refrigerator will detect when the supply of certain items is running low and will communicate this, so that it can be refurnished. The washing machine will determine how much



Figure 1.23 House of the future [4]

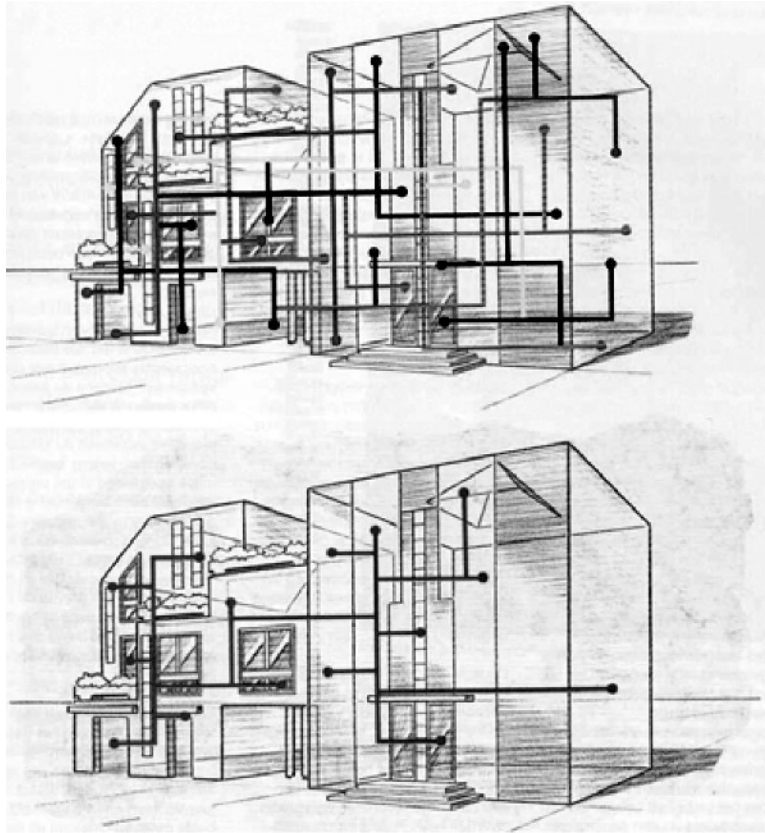

Figure 1.24 A smart home with a sensor bus system instead of a point-to-point sensor system [4]



Figure 1.25 Cleaning a house with an iRobot® Roomba® Autonomous Vacuum Cleaner

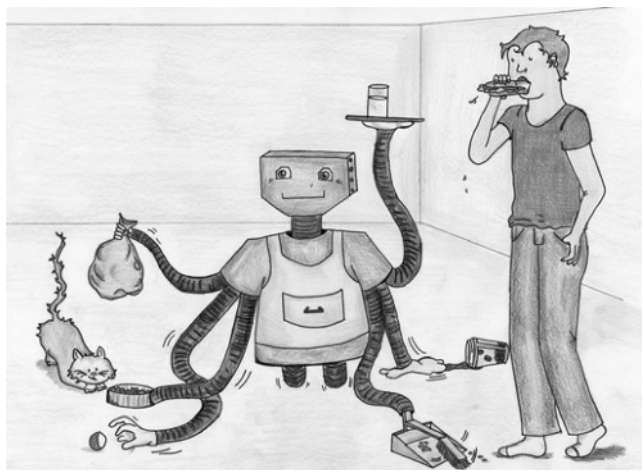

Figure 1.26 House robot (picture Inge van der Lee)

detergent is needed to clean the laundry and use no more than that. It will rinse until no soap is left in the laundry – not a second longer. It will immediately start rinsing if a red sweater threatens to turn the laundry pink.

There may be a time when every house comes with a robotic butler, supplying the needs of the family members (Figure 1.26). Only integrated smart sensors can enable this.

1.4.4 Smart Toys

Toys can become lifelike if they are given sensors. An example is the Sony AIBO of Figure 1.27.

Sensors used in virtual-reality gloves can monitor our movements so that the virtual reality we see can be adapted to it (Figure 1.28).



Figure 1.27 AIBO (courtesy of Sony Benelux B.V.)



Figure 1.28 Virtual reality feeling and vision (courtesy of Sunrise Virtual Reality, Inc.)



Figure 1.29 Playing tennis around the world (picture Inge van der Lee)

A racing simulator may be used for play or driving instructions. And now it is even possible to play a (table) tennis match with someone at the other side of the world (see Figure 1.29).

1.5 Conclusion

We have shown why the third industrial revolution can only become reality through smart sensor systems. A definition of smart sensor systems has been given. Applications have been discussed in the fields of automated production machines and automated consumer products.

References

1. Middelhoek, S. and Audet, S.A. (1989). *Silicon Sensors*, Academic Press. Reproduced by permission of S.Middelhoek.
2. Ohba, R. (1992). *Intelligent Sensor Technology*, John Wiley & Sons, Ltd, Chichester.
3. Centrum voor Micro-Elektronica (1993). *Use of Sensors and Actuators in the German and Dutch Machine Building Industries*. Reproduced by permission of Ton van Schadewijk.
4. Titulaer, C. and de Kort, N. (1991). *Kantoor van de Toekomst*, Chriet Titulaer Producties, Houten. Reproduced by permission of Chriet Titulaer.

